

ESCANTILLON

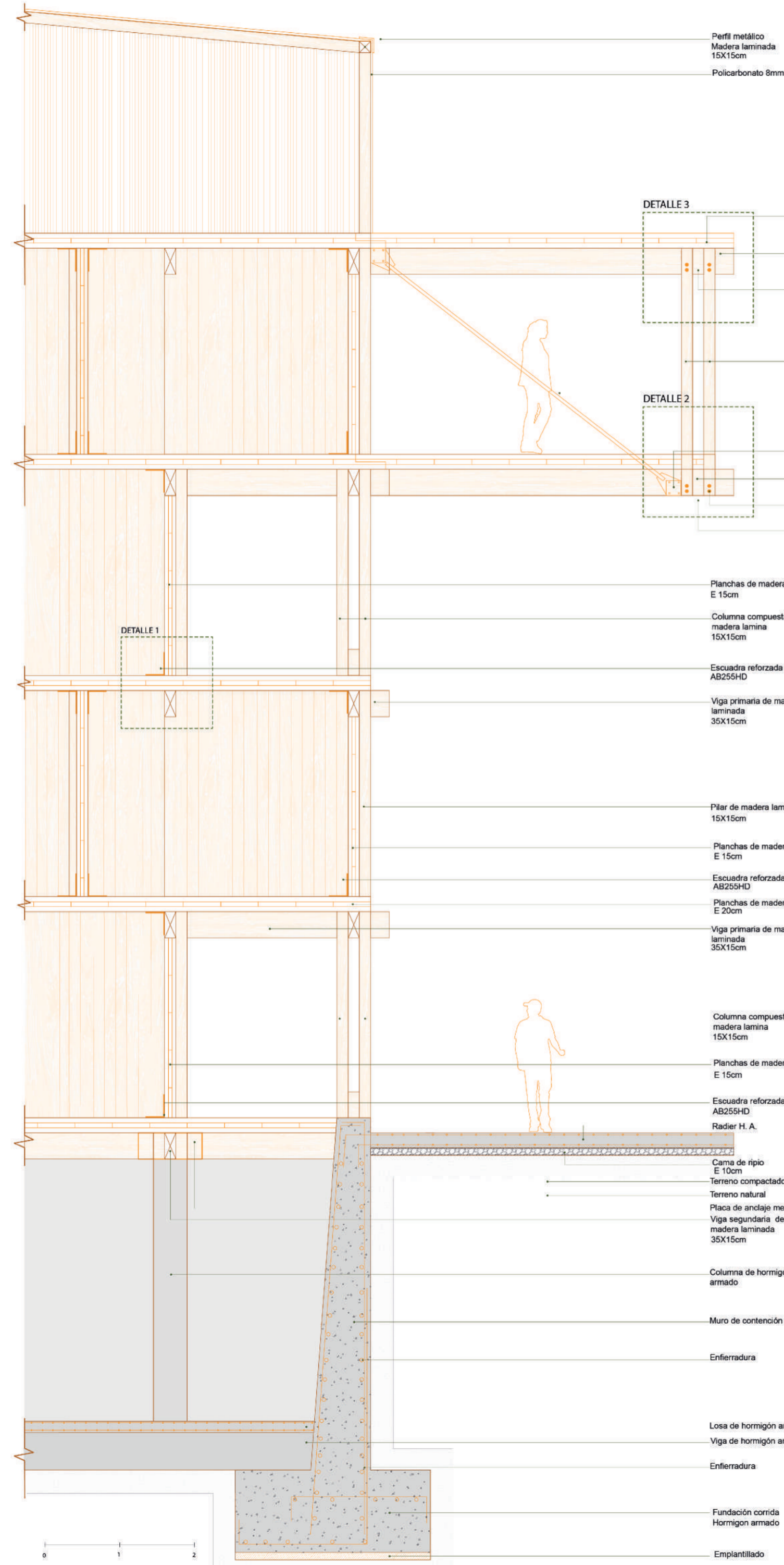

DETALLES CONSTRUCTIVOS

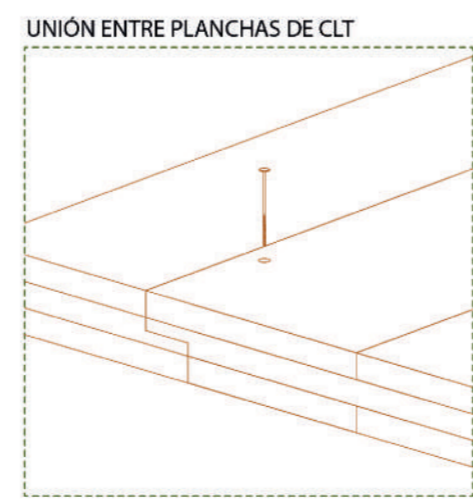
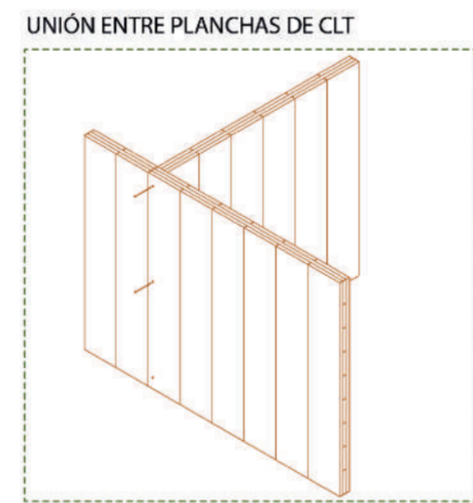
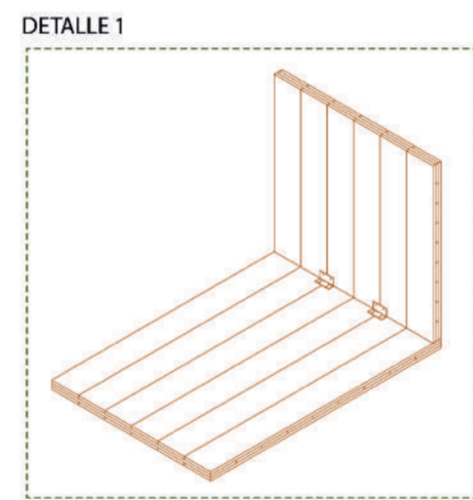
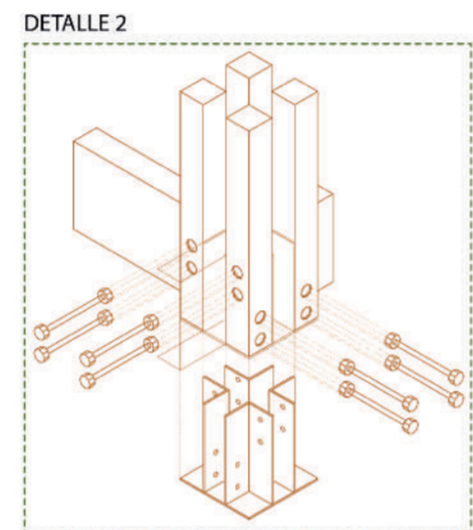
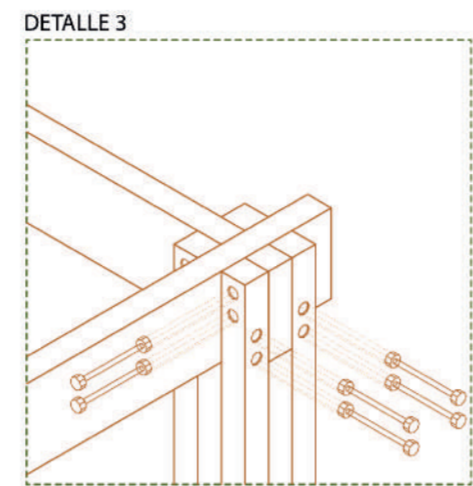
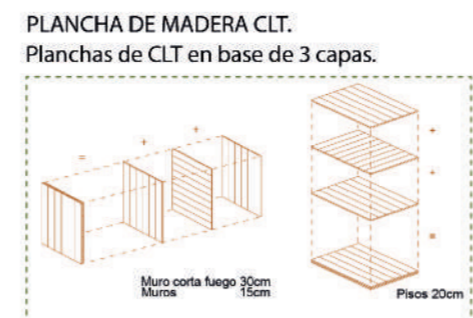

CONSTRUCCION E INDUSTRIALIZACION

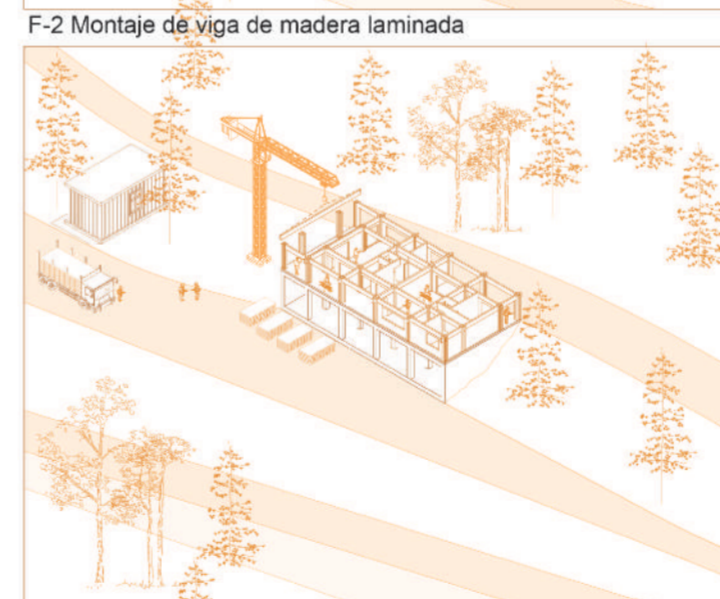
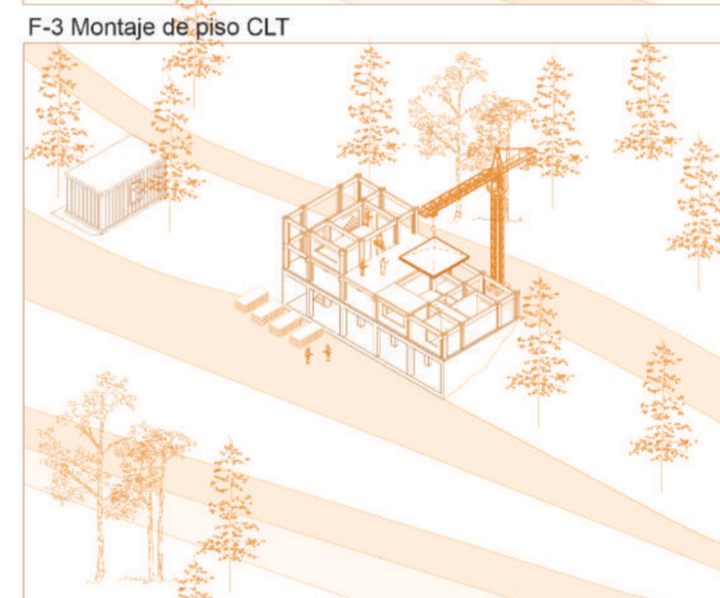
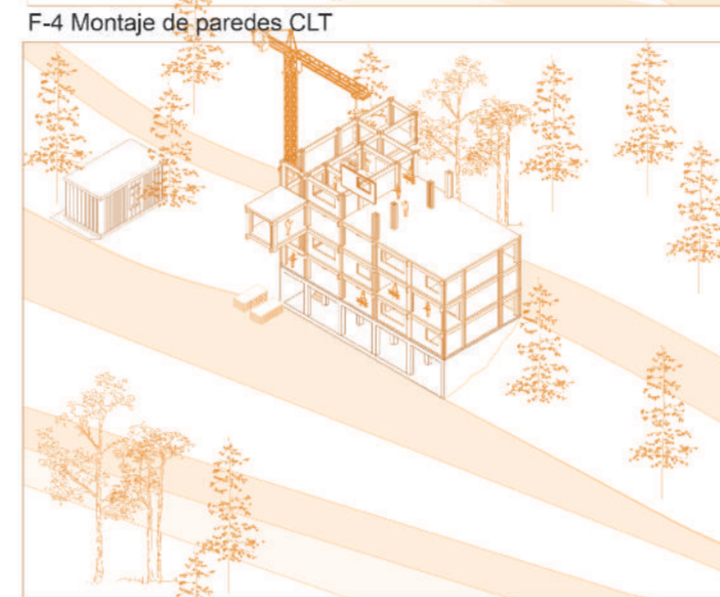

ISOMETRICA EXPLOTADA

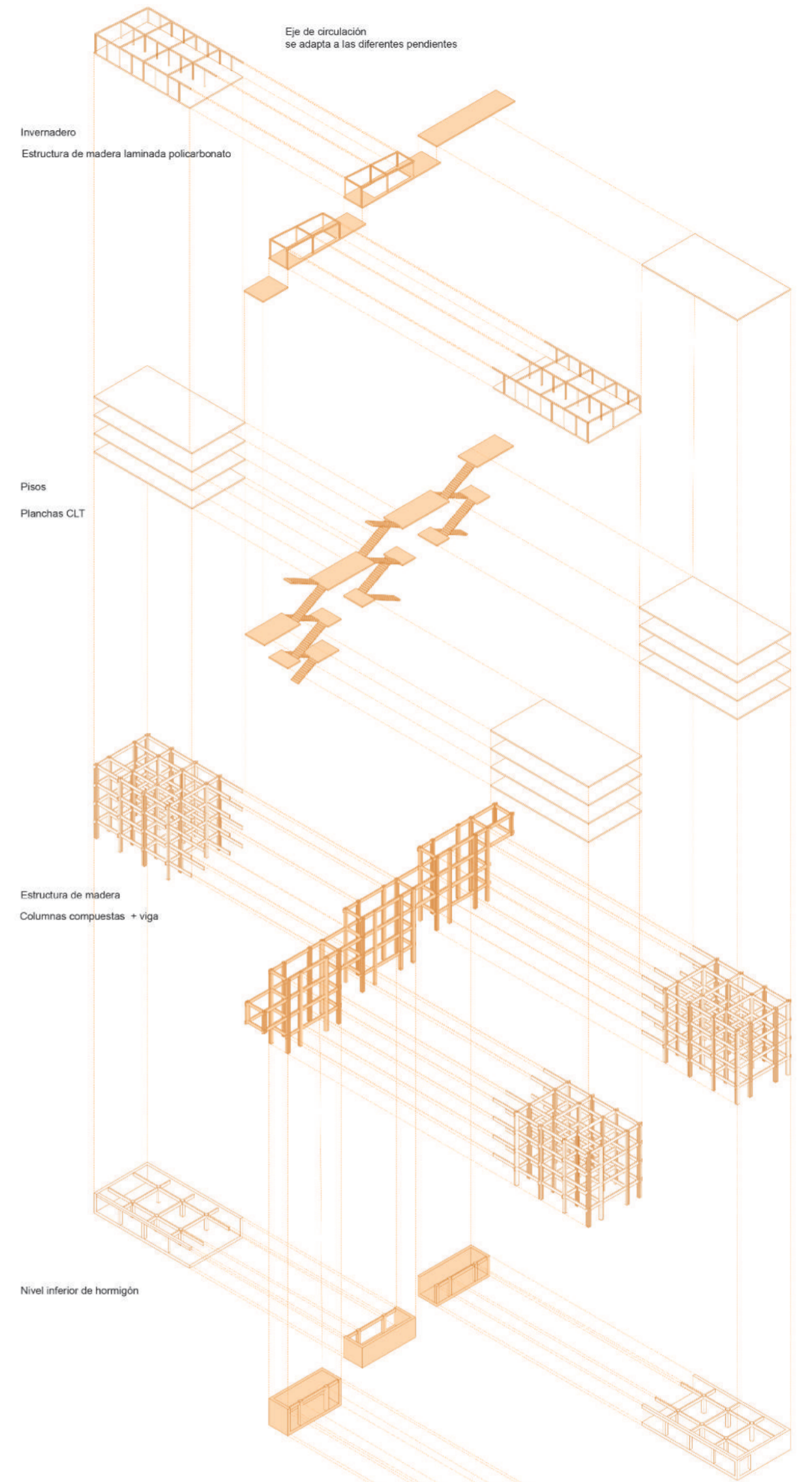

ISOMETRICA CONJUNTO

