

ANÁLISIS ESTRUCTURAL

CELOSIAS MADERA Y TECHO CLT

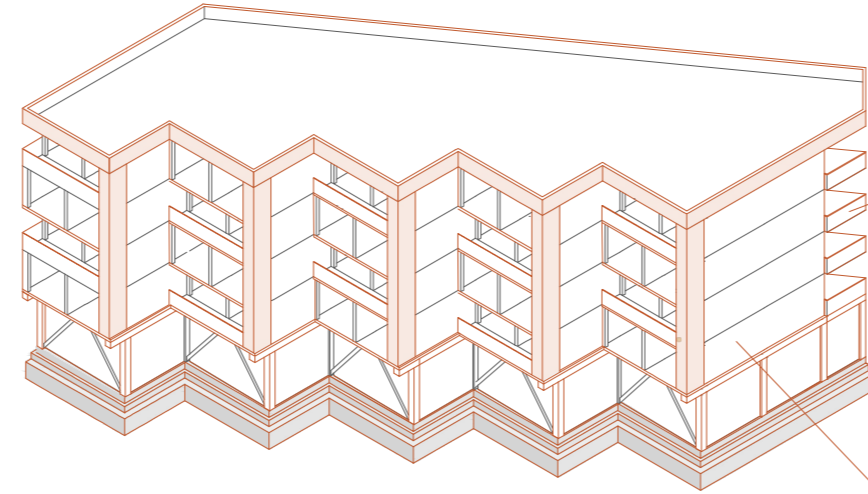

ESCALERAS Y BARANDAS

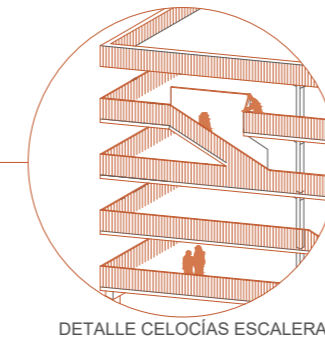
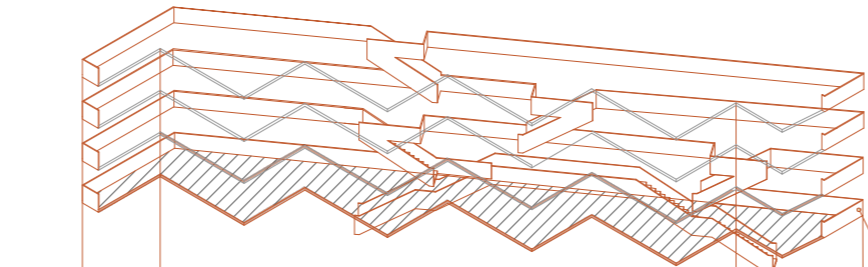

CERRAMIENTO MUROS TABIQUERÍA DE MADERA

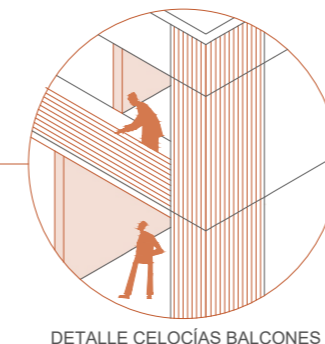
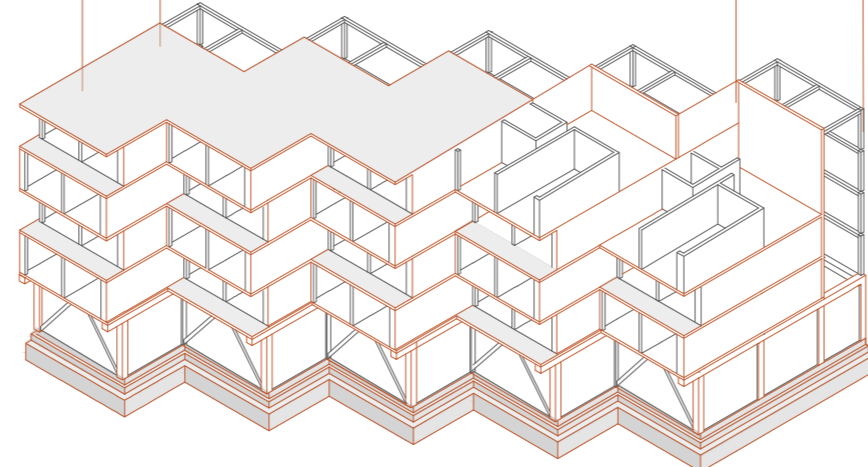

SUELO, TECHO Y MUROS ESTRUCTURALES DE CLT

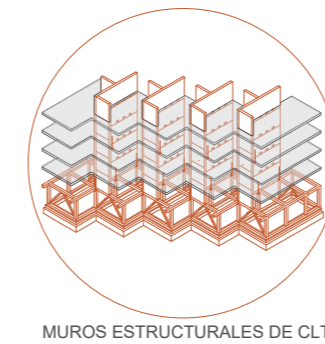
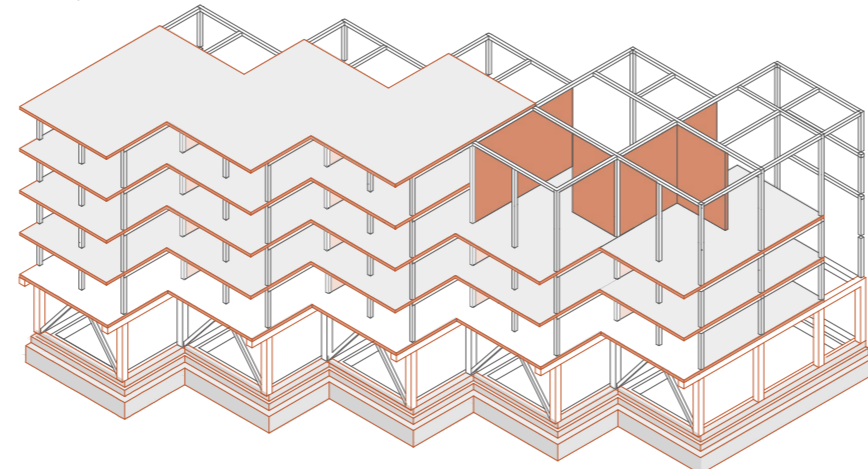

ENTRAMADO DE MADERA VIVIENDAS

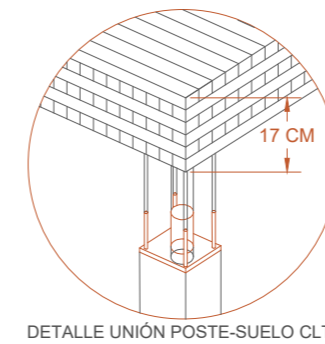
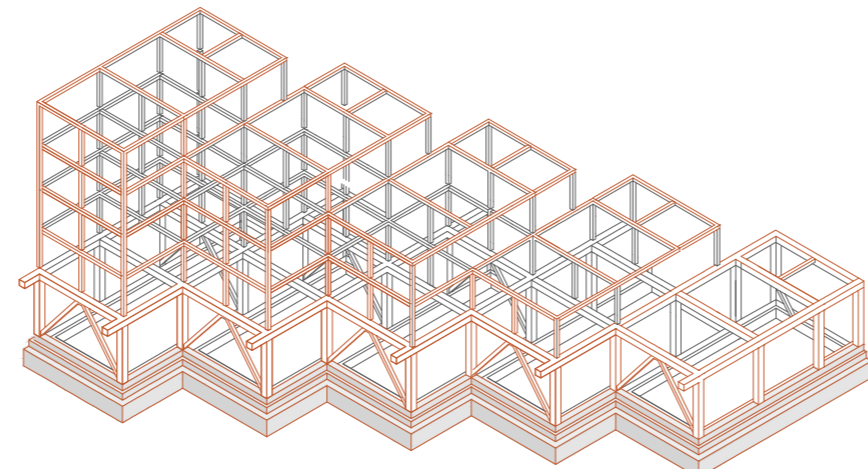

ENTRAMADO PORTANTE DE MADERA, ARRIOSTAMIENTO, FUNDACIONES HAY MUROS ESTRUCTURALES CLT

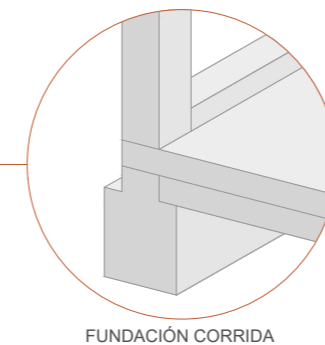
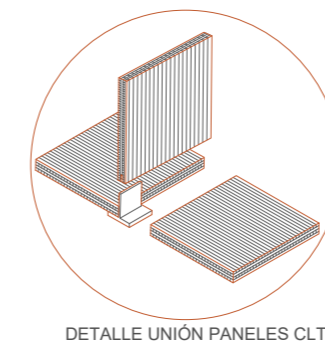
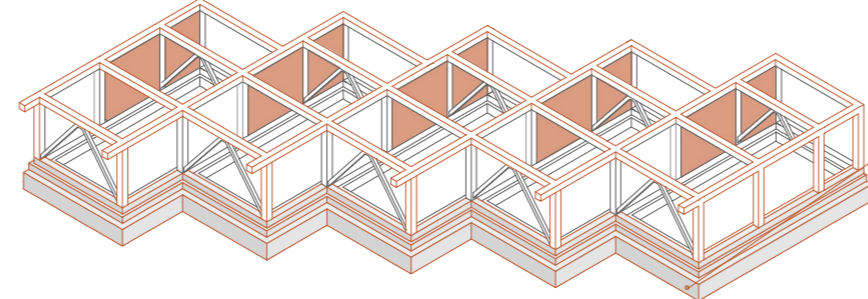

ESCANTILLÓN

